

Part Number: AE-SC24304H

10/100/1000 BASE LAN TRANSFORMER

- Compliant with IEEE802.3 requirement.
- RoHS compliant.
- Operating temperature range:-40°C to +85°C.
- Storage temperature range:-40°C to +125°C.

**Electrical Specifications @ 25°C**

Part Number	Turns Ratio (±5%)	OCL(μH Min) @100KHz/0.2V With 8.0mA DC	Insertion Loss (dB Max)	DCMR (dB Min)			DCR (Ω Max)	HI-POT (Vrms) 1mA/60S
			1-100MHz	30MHz	60MHz	100MHz		
AE-SC24304H	1CT:1CT	350	-1.2	-40	-35	-28	1.4	1500

**Continue**

Part Number	Return Loss (dB Min)				Cross Talk (dB Min)			LK (μH Max)	CWW (pF TYP)
	1-30MHz	40MHz	50MHz	60-80MHz	30MHz	60MHz	100MHz	@100KHz/0.2V	@100KHz/0.2V
AE-SC24304H	-16	-14	-13	-12	-42	-36	-30	0.5	20

**Mechanicals:**

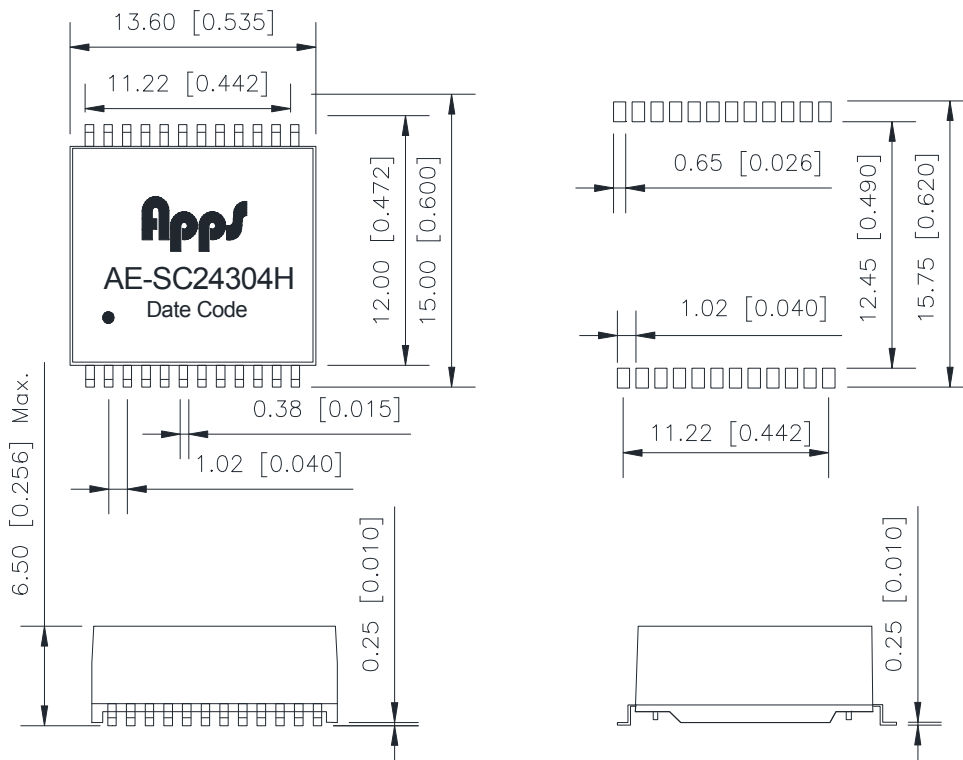

Dimension:mm[Inch]±0.25[0.010]

# Part Number: AE-SC24304H

## 10/100/1000 BASE LAN TRANSFORMER

**Schematics:**

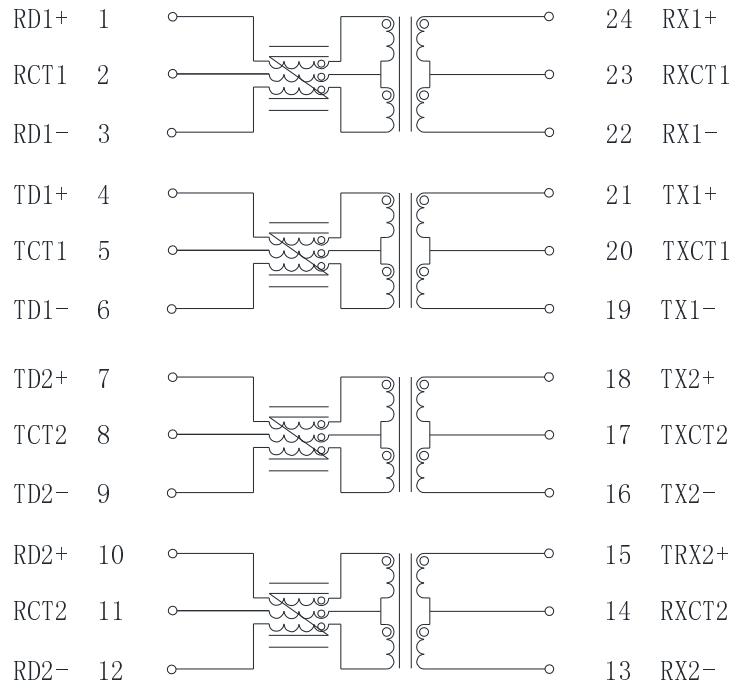

**Package:**

